

STORMWATER MANAGEMENT REPORT

YORK ROAD RESIDENTIAL INFILL 1317 York Road Niagara-on-the-Lake, ON

*Prepared by: Quartek Group Inc.
Engineers, Architects & Planners
89-91 St. Paul Street, Suite 100
St. Catharines, ON
905-984-8676
www.quartekgroup.com*



QGI File: 24086

Mar 2026

STORMWATER MANAGEMENT REPORT

YORK ROAD RESIDENTIAL INFILL 1317 York Road Niagara-on-the-Lake, ON

1. Background Information

1.1. Site Conditions

Site Location: 1317 York Road, Niagara-on-the-Lake, ON

Site Area: ±0.26 ha (SWM Site – includes some area outside the property)

Land Use: Existing: R1 – Low Density Residential Zone
Proposed: Residential townhouse dwellings and one (1) single detached dwelling (6 units total)

Receiving Storm Sewers: 600mmØ concrete STM on the west side of Tanbark Road (west of site)
300mmØ concrete STM on the south side of York Road (east of site)

1.2. Background

This report summarizes the stormwater management design for the proposed 6-unit residential development. An aerial view of the site is provided in Figure 1-1.

The subject site is located on the SE corner of the York Road and Tanbark Road intersection in Niagara-on-the-Lake. There are low density residential dwellings, parkland and a school in close proximity to the property.

There is an existing residential dwelling and garden shed on the property (both to be demolished). Other existing features on the property are concrete walkways, patio stones, small retaining walls and trees of various sizes. Much of the property is grass area. The land has minimal slopes that aim towards both roads – the majority of the property drains northeast though. Regardless of the runoff direction, stormwater eventually reaches existing curb & gutter on either York or Tanbark Road, ultimately conveyed by the respective storm sewer. As noted, there is an existing 600mmØ concrete STM located on the west side of Tanbark Road. In addition, there is an existing 300mmØ concrete storm on the south side of York Road, east of the subject property.



Figure 1-1: Aerial View of Site

1.3. Development Proposal

The proposed development is for five (5) residential townhouse units, in one (1) block, as well as one (1) single detached dwelling unit. The impervious areas after development include roof and asphalt pavement. The pervious areas are landscaping areas.

The current site drainage system is overland, with no pronounced/functioning swales. There is curb and gutter along the west and north sides of the property, which conveys runoff to the aforementioned storm sewers.

1.4. Runoff Characteristics and Criteria

It is understood that stormwater management will be required (as specified by the Region) to ensure both the 5-year and 100-year post-development peak flows be controlled to the 5-year pre-development peak flow level prior to discharge from the site to the York Road storm sewer.

The runoff characteristics and design criteria for the site can be summarized as follows:

- The existing SWM Site area is calculated as 84.3% pervious and 15.7% impervious.
- The proposed site plan contains an impervious area of 0.10 ha totalling 38.5% of the entire drainage area and consists of roofs and driveways with an SCS curve number of 98. The remainder pervious area is grass and sod in good condition with an SCS curve number of 75.

1.5. Design Storm Characteristics

The defining parameters for the design storm used for modelling are the IDF Curves and Storm Depths given in the Town of Niagara-on-the-Lake Municipal Engineering Standards Manual (2004), which uses the City of St. Catharines IDF curves and a 3-hour duration. These parameters are summarized in Table 1-1 below and have been incorporated in the computerized modelling. Although the 300mmØ storm on York Road is a regional sewer, the proposed 200mmØ storm sewer connecting the development to the regional sewer will be assumed by the Town.

Table 1-1: Design Storm Parameters

Storm Return Period	IDF Curve Parameters			Maximum intensity (mm/hr)	Total Depth (mm)
	a	b	c		
5 year	664	4.7	0.744	120.81	41.02
100 year	980	3.7	0.732	198.43	64.72

**rainfall intensity, $I = a/(t+b)^c$, where t = time of concentration (min.)
Ratio of time to peak = 0.375*

2. Minor & Major Storm Drainage System and Quantity Management

Software modelling for the 5-year and 100-year return period storm was performed using MIDUSS (Micro Interactive Design of Urban Storm Sewers) software. Details of the

MIDUSS output can be viewed in Appendix A. Pre-development and post-development peak flows for the 5-year and 100-year return period storms are shown in Table 2-1 & 2-2.

Currently, in pre-development conditions, Catchment 101 drains overland to Tanbark Road. It has been noted by the Town that there are capacity constraints downstream of the 600mmØ storm sewer on Tanbark Road, at an existing SWM facility. The Town stated that a storm connection to Tanbark Road cannot be supported. Catchment 102 drains overland to York Road.

In the post-development scenario, runoff from Catchment 201 will drain overland to Tanbark Road, matching pre-development conditions. In order to match the pre-development peak flows to Tanbark Road, all runoff generated from proposed roof areas will drain either to the rear/sides of the proposed buildings. Given the proposed townhouse block roof design, three (3) 100mmØ storm laterals are proposed within Catchment 202, which will be connected to interior piping within the townhouse basements to convey runoff from the front central location of the roof to the underground stormwater detention system. Runoff in Catchment 202 will be conveyed either overland or in swales to either one of two (2) proposed catchbasins or catchbasin maintenance hole (CBMH1). CBMH1 is the furthest downstream structure within the subject property and its outlet pipe will connect to the existing catchbasin on York Road.

Table 2-1: Peak Flow Pre-Development

Catchment Area	5-Year Peak Outflow (m ³ /s)	100-Year Peak Outflow (m ³ /s)
101 (Tanbark)	0.003	0.007
102 (York)	0.008	0.021

Table 2-2: Peak Flow Post-Development

Catchment Area	5-Year Peak Outflow (m ³ /s)	100-Year Peak Outflow (m ³ /s)
201 (Tanbark)	0.003	0.007
202 (York)	0.006 (Controlled)	0.008 (Controlled)

The on-site storage output for the minor/major system stormwater storage is shown in Table 2-3 below.

Table 2-3: On-Site Storage

Design Storm	Design	On-Site Storage Provided
	Underground Storage Volume Required (m ³)	Underground Chamber Storage (m ³)
5	15.7	42.0
100	37.5	42.0

The Solflo Max 900mmØ HDPE underground detention system can provide temporary detention and restrict flow by using a tempest inlet control device at CBMH1. A data sheet for Solflo Max HDPE piping is included as Appendix B – tees, crosses and 90° bends are available to create an interconnected detention system.

The storage volume provided in the on-site detention system is adequate to restrict the peak post-development flows (5-year and 100-year) to the 5-year pre-development peak flow level.

Grading design will direct minor storm runoff to the on-site collection points. Site grading will also take into consideration the existing grades along all boundaries to ensure there is no impact on adjacent properties.

Attachments

1. Drawing 24086-CSS – Conceptual Site Servicing
2. Drawing 24086-STM-1 – Pre-Development Storm Drainage Areas
3. Drawing 24086-STM-2 – Post-Development Storm Drainage Areas
4. Appendix A: MIDUSS Model Output
5. Appendix B: Solflo Max Data Sheet
6. Appendix C: Tempest Inlet Control Device Flow Chart (LMF-105)

Stormwater Management Report

Prepared by: T. Crawford, C.E.T., Quartek Group Inc.

Reviewed by: H. Klassen, P.Eng., Quartek Group Inc.



GENERAL

- 1. PRIOR TO CONSTRUCTION THE CONTRACTOR SHALL CHECK AND VERIFY ALL DIMENSIONS AND EXISTING ELEVATIONS WHICH INCLUDE BUT ARE NOT LIMITED TO THE BENCHMARK ELEVATIONS, EXISTING SERVICE CONNECTIONS, AND EXISTING INVERTS. ANY INCONSISTENCIES AND OMISSIONS ON THIS DRAWING / DRAWING SET SHALL BE REPORTED TO THE ENGINEER FOR CLARIFICATION BEFORE COMMENCING THE WORK.
2. THE POSITION OF POLE LINES, CONDUITS, WATERMANS, SEWERS AND OTHER UNDERGROUND AND ABOVE GROUND UTILITIES AND STRUCTURES ARE NOT NECESSARILY SHOWN ON THE CONTRACT DRAWINGS, AND WHERE SHOWN, THE ACCURACY OF THE POSITION OF SUCH UTILITIES AND STRUCTURES IS NOT GUARANTEED. BEFORE STARTING WORK, THE CONTRACTOR SHALL CONFIRM THE EXACT LOCATION OF ALL SUCH UTILITIES AND STRUCTURES, AND SHALL ASSUME ALL LIABILITY FOR DAMAGE TO THEM.
3. SURVEY EVIDENCE (MONUMENTS, IRON BARS, ETC.) SHALL NOT BE DISTURBED, DAMAGED, OR REMOVED.
4. COMPUTER DRAWING FILE CO-ORDINATES FOR THIS DRAWING SHALL NOT BE USED FOR CONSTRUCTION LAYOUT UNLESS SPECIFICALLY DIRECTED BY THE ENGINEER.
5. ALL WORK SHALL BE COMPLETED IN ACCORDANCE WITH THE OCCUPATIONAL HEALTH AND SAFETY ACT. THE GENERAL CONTRACTOR SHALL BE DEEMED TO BE THE CONSTRUCTOR AS DEFINED IN THE ACT.
6. ALL CONSTRUCTION SIGNAGE SHALL CONFORM TO THE MANUAL OF UNIFORM TRAFFIC CONTROL DEVICES FOR CANADA (MUTCD) AND THE ONTARIO TRAFFIC MANUAL (OTM).
7. TOWN OF NIAGARA-ON-THE-LAKE STANDARD DRAWINGS AND ONTARIO PROVINCIAL STANDARD DRAWINGS (OPSD) SHALL APPLY WHEREVER RELEVANT, WHETHER SPECIFICALLY REFERENCED OR NOT.
8. ALL WORK SHALL BE IN ACCORDANCE WITH THE RELEVANT SECTIONS OF THE ONTARIO PROVINCIAL STANDARD SPECIFICATIONS (OPSS) AND DRAWINGS (OPSD), AND THE NIAGARA PENINSULA STANDARD CONTRACT DOCUMENT (NPSCD) UNLESS OTHERWISE NOTED ON THE DRAWINGS OR IN THE SPECIFICATIONS.
9. ALL MEASUREMENTS ARE IN METRES UNLESS OTHERWISE NOTED.
10. ALL GRANULAR MATERIAL SHALL BE COMPACTED TO 100% STANDARD PROCTOR MAXIMUM DRY DENSITY (SPMDD) AND ALL NATIVE BACKFILL SHALL BE COMPACTED TO 95% SPMDD UNLESS OTHERWISE NOTED.
11. ALL AREAS DISTURBED BY THE CONTRACTOR DURING THE CONSTRUCTION OF THE WORKS HEREIN, SHALL BE RESTORED TO ORIGINAL CONDITION OR BETTER AS DETERMINED BY THE ENGINEER. ALL GRASS AND VEGETATION COVERED AREAS SHALL BE RESTORED BY PLACING TOPSOIL (MINIMUM 100mm) AND SOD TO ESTABLISH A GRASS COVER TO THE SATISFACTION OF THE TOWN, UNLESS NOTED OTHERWISE.
12. SOD SHALL BE IN ACCORDANCE WITH OPSS 803. PLACED TOPSOIL SHALL BE IN ACCORDANCE WITH OPSS 802 AND FREE OF ALL GRANULAR PARTICLES OR OTHER MATERIALS DELETERIOUS TO PLANT GROWTH.

EROSION AND SEDIMENT CONTROL

- 13. EROSION AND SEDIMENT CONTROL WORKS SHALL BE INSTALLED AS SHOWN ON DRAWING 24086-CSS. SILTATION CONTROL MEASURES SHALL BE IN PLACE PRIOR TO THE START OF CONSTRUCTION AND MAINTAINED FOR THE DURATION.
14. SILT FENCE SHALL BE HEAVY-DUTY AS PER OPSD 219.130. GEOTEXTILE MATERIAL FOR ANY APPLICATION SHALL BE WOVEN WITH A WEAVE DENSITY OF 270R OR EQUIVALENT.
15. SILT FENCE INSTALLATION AND MAINTENANCE CONSIDERATIONS:
15.1. GEOTEXTILE MATERIAL SHALL BE STRETCHED TIGHT DURING INSTALLATION AND THE BOTTOM EDGE BURIED A MINIMUM OF 150mm WITH COMPACTION OF THE EXCAVATED BACKFILL.
15.2. CLEAR GRANULAR STONE PLACEMENT CAN BE USED IN FROZEN OR UNFROZEN CONDITIONS TO ASSIST IN FILTERING SEDIMENT LADEN WATERS.
15.3. SILT FENCE SHALL BE INSPECTED REGULARLY AND AFTER EVERY RAINFALL TO IDENTIFY FAILED SECTIONS. ANY FAILURE SHALL BE REPAIRED IMMEDIATELY.
15.4. WHEN SEDIMENT ACCUMULATES TO HALF THE HEIGHT OF THE GEOTEXTILE MATERIAL IT SHALL BE REMOVED AND DISPOSED OF IN A CONTROLLED AREA.
15.5. A SUPPLY OF SILT FENCE SHALL BE KEPT ON SITE TO PROVIDE FOR QUICK REPAIRS OR ADDITIONAL FENCING REQUIREMENTS.
16. GEOTEXTILE MATERIAL SHALL BE PLACED UNDER THE GRATES IN ALL CATCH BASINS TO TRAP SEDIMENT. SILT TRAPS SHALL BE CLEANED REGULARLY BY THE CONTRACTOR AND SHALL NOT BE REMOVED UNTIL PAVEMENT OPERATION IS COMPLETED AND ALL VEGETATED AREAS ARE STABILIZED.

ROADS AND EARTHWORKS

- 17. WHERE DISTURBED OR DAMAGED, REINSTATEMENT OF EXISTING ROADS MUST COMPLY WITH THE REQUIREMENTS OF THE ROAD AUTHORITY. PAVEMENT REINSTATEMENT MUST COMPLY WITH OPSD 509.010 AND OPSD 310 & 314. SERVICE TRENCHES ARE TO BE SAWCUT SQUARE PRIOR TO PAVING OPERATION. MINIMUM ASPHALT AND GRANULAR THICKNESS FOR ROADWAY REINSTATEMENT SHALL MATCH EXISTING CONDITIONS, OR THE SCHEDULE BELOW, WHICHEVER IS GREATER:

Table with 2 columns: COURSE, THICKNESS. Rows include SURFACE COURSE (40mm HL3-HS), BINDER COURSE (80mm HL8-HS), GRANULAR BASE (450mm GRAN. 'A'), and TOTAL THICKNESS (570mm).

STORM SEWERS

- 18. CONSTRUCTION OF STORM SEWERS SHALL BE IN ACCORDANCE WITH TOWN STANDARDS & SPECIFICATIONS (LATEST EDITION) AND MINISTRY OF ENVIRONMENT (MOE) GUIDELINES (LATEST EDITION).
19. SINGLE CATCH BASINS SHALL BE IN ACCORDANCE WITH OPSD 705.010.
20. CATCH BASIN FRAME AND GRATES SHALL BE PER OPSD 400.020.
21. ALL STORM SEWERS AND CATCHBASIN LEADS SHALL BE EITHER CONCRETE, CLASS III PER CSA A257.1 & A257.2 WITH CLASS 'B' BEDDING PER OPSD 802.030, OR PVC SDR-35 PER CSA 182.1 & 182.2 WITH GRANULAR 'A' EMBEDMENT PER OPSD 802.010, UNLESS OTHERWISE NOTED.
22. ALL STORM LATERALS TO BE 100mm DR-28 PVC LAID AT 2% SLOPE CONNECTED TO PROPOSED STORM DETENTION SYSTEM AND CAPPED & STAKED OUTSIDE OF PROPOSED FOUNDATION.
23. STORM SEWER BEDDING SHALL BE PER OPSD 802 SERIES, WITH GRANULAR 'A' COVER. ALL BEDDING AND COVER MATERIAL SHALL BE COMPACTED TO 100% SPMDD.
24. MINIMUM CLEARANCE OF 200mm SHALL BE PROVIDED BETWEEN THE OUTSIDE OF THE PIPE BARRELS AT THE POINT OF PIPE CROSSING FOR SEWERS AND OTHER UTILITIES EXCEPT FOR WATERMAIN CROSSINGS. WHEN THE MINIMUM CLEARANCE SHALL NOT BE LESS THAN 500mm, FOR WATERMAIN CROSSINGS WHERE A MINIMUM CLEARANCE OF 500mm CANNOT BE OBTAINED, THE CROSSING SHALL BE CONCRETE ENCASED.

SANITARY SEWERS

- 25. CONSTRUCTION OF SANITARY SEWERS SHALL BE IN ACCORDANCE WITH CITY STANDARDS & SPECIFICATIONS (LATEST EDITION) AND MINISTRY OF ENVIRONMENT (MOE) GUIDELINES (LATEST EDITION).
26. ALL SANITARY LATERALS TO BE 135mm DR-28 PVC LAID AT 2% SLOPE AND CONNECTED TO EXISTING SEWER WITH APPROVED MANUFACTURED TEE AND CAPPED & STAKED NEAR THE STREETLINE. SANITARY SERVICE LATERALS SHALL BE CONSTRUCTED WITH A 100mm PVC VERTICAL CLEANOUT CONNECTION AT THE PROPERTY LINE. ALL PROPOSED WYES AND BENDS SHALL BE OF 'SWEEP' OR 'LONG-RADIUS' TYPE.
27. ALL SANITARY LATERALS SHALL HAVE CLASS 'B' BEDDING PER OPSD 802.010, GRANULAR 'A' COVER MATERIAL AND SELECT NATIVE BACKFILL UNLESS OTHERWISE NOTED.
28. IN EXISTING ROADWAYS, SANITARY SEWER BEDDING SHALL BE AS PER OPSD 802 SERIES, WITH FULL GRANULAR 'A' COVER. ALL BEDDING AND COVER MATERIAL SHALL BE COMPACTED TO 100% SPMDD.
29. MINIMUM CLEARANCE OF 200mm SHALL BE PROVIDED BETWEEN THE OUTSIDE OF THE PIPE BARRELS AT THE POINT OF PIPE CROSSING FOR SEWERS AND OTHER UTILITIES EXCEPT FOR WATERMAIN CROSSINGS. WHEN THE MINIMUM CLEARANCE SHALL NOT BE LESS THAN 500mm, FOR WATERMAIN CROSSINGS WHERE A MINIMUM CLEARANCE OF 500mm CANNOT BE OBTAINED, THE CROSSING SHALL BE CONCRETE ENCASED.

WATERMAIN

- 30. WATER SERVICES SHALL BE 25mm TYPE 'K' SOFT COPPER AS PER OPSD 1104.010. ALL DOMESTIC WATER SERVICE CONNECTIONS SHALL HAVE MAINSTOPS (COMPRESSION TYPE FITTINGS) INSTALLED AT THE WATERMAIN EQUAL TO THE WATER SERVICE CONNECTION DIAMETER. CURB STOP AND VALVE BOX SHALL BE INSTALLED ON PROPERTY LINE. AT EACH SERVICE SADDLE WATERMAIN PIPE SHALL BE CORED BY A 19mm 'SHELL' OR 'CORE' CUTTER AS RECOMMENDED BY THE PIPE MANUFACTURER. A HOLESAW, TWIST DRILL, SPADE OR AUGERING BIT WILL NOT BE PERMITTED UNDER ANY CIRCUMSTANCE.
31. CONNECTIONS TO EXISTING TOWN WATERMANS SHALL BE BY TOWN FORCES UNLESS AUTHORIZED OTHERWISE.
32. MINIMUM DEPTH OF COVER OVER WATERMAIN AND SERVICES SHALL BE 1.7m FROM THE TOP OF PIPE TO THE FINISHED GROUND ELEVATION.

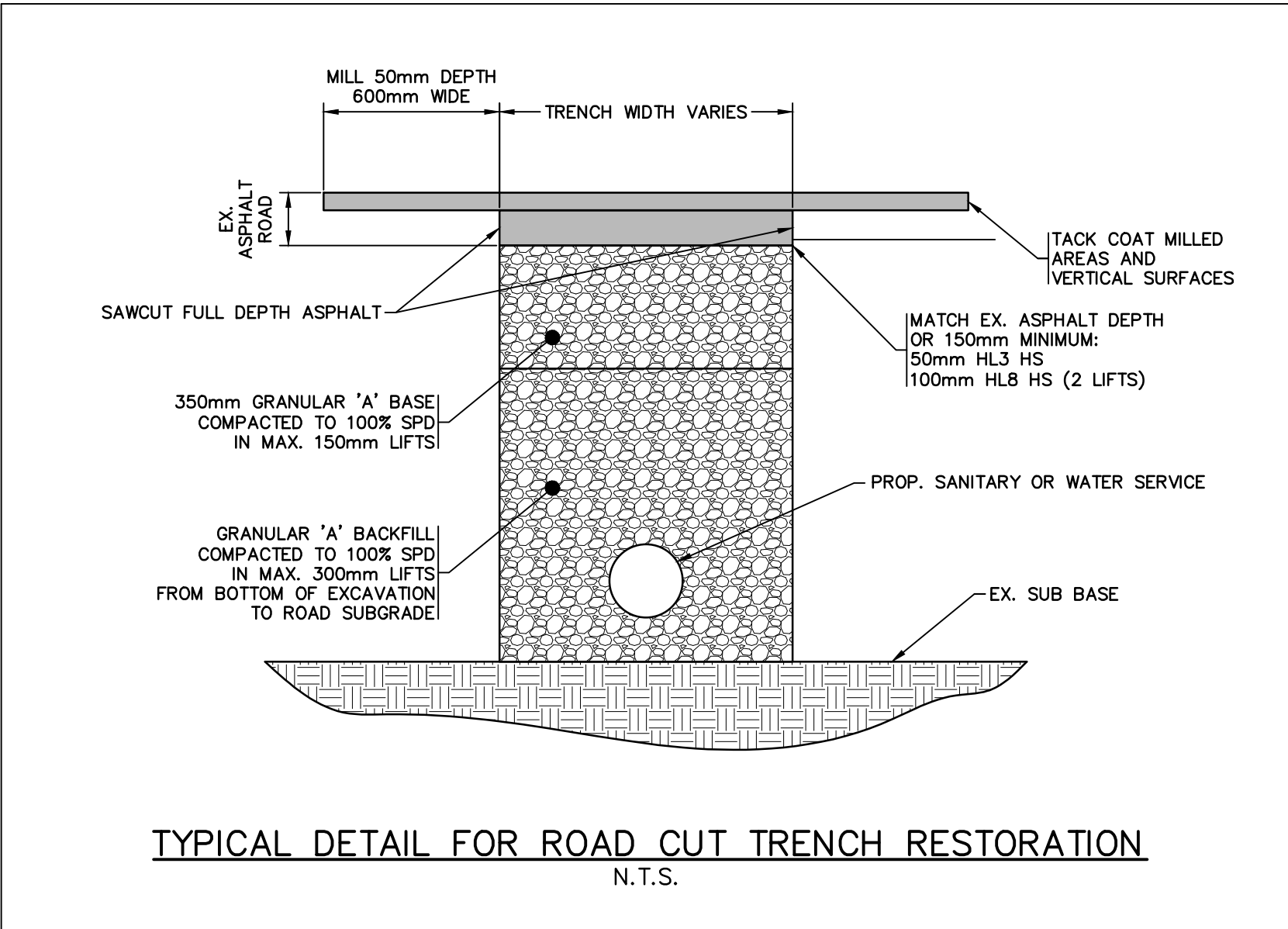
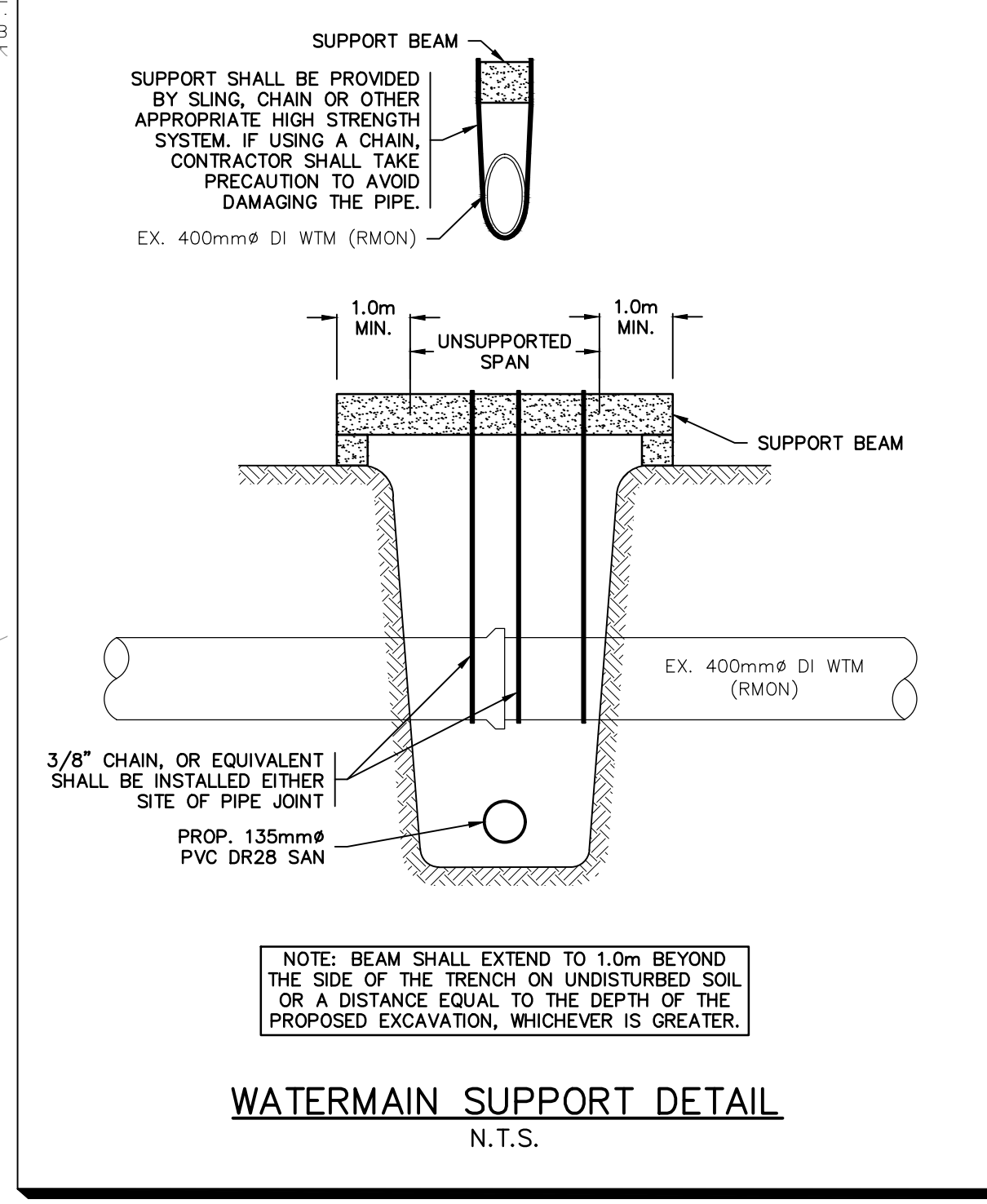
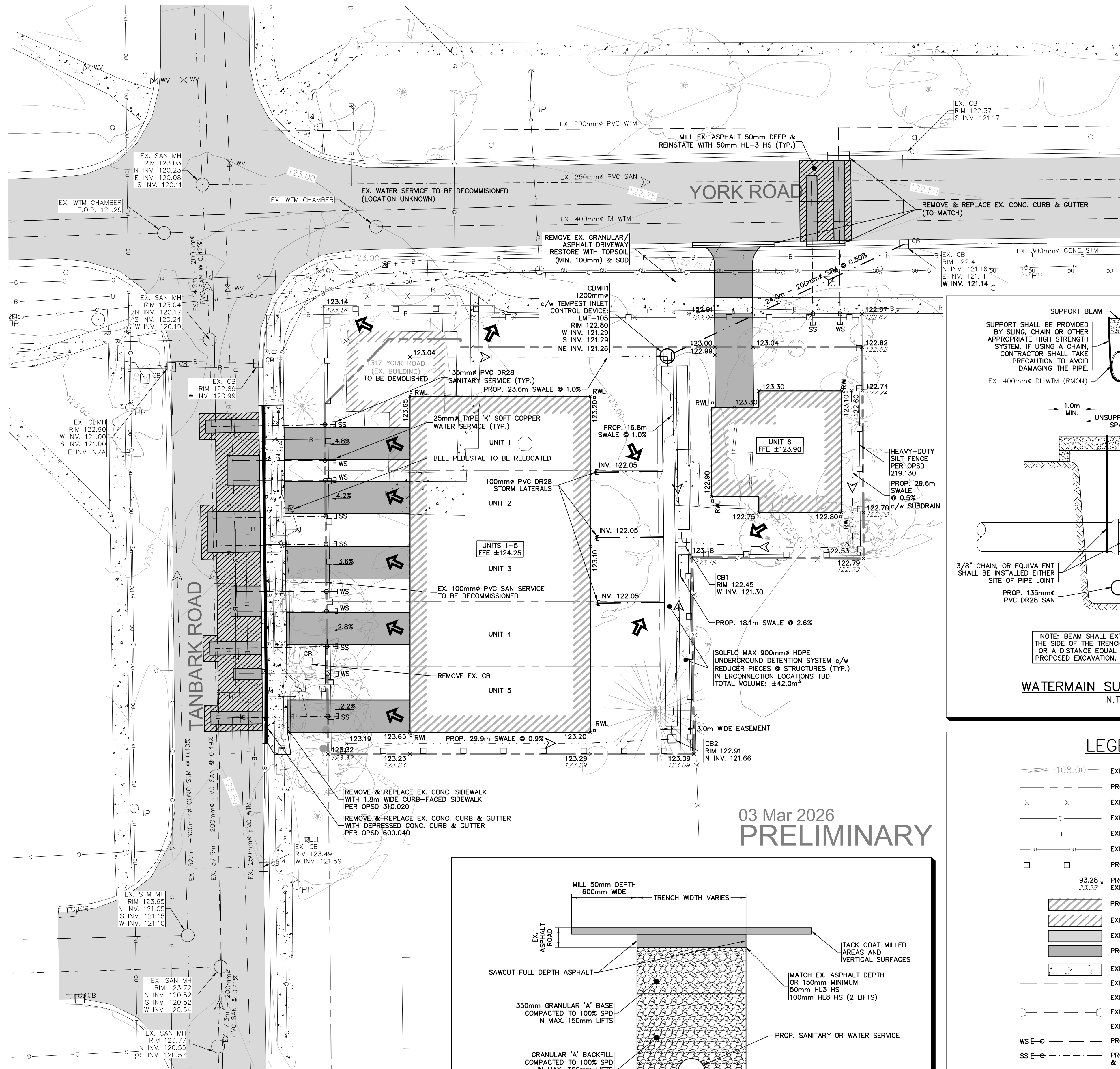

LEGEND section containing symbols for ground contours, property lines, fences, utilities, buildings, and various pipe types.

Revision table with columns for issue number, description, date, and initials.

B OPAZBA RESUBMISSION 03 MAR 2026 TC
A OPAZBA APPLICATION 10 JULY 2025 TC
Issue issued for date int.

Do not scale drawings. Report any discrepancies to Quartek Group Inc. before proceeding.
Drawings must be sealed by the Architect and / or Engineer prior to the use for any building permit applications and / or government approval. Seals must be signed by the Architect and / or Engineer before drawings are used for any construction.
All construction to be in accordance with the current Ontario Building Code and all applicable Ontario regulations.
All drawings and related documents remain the property of Quartek Group Inc., all drawings are protected under copyright and under contract.

Quartek logo and contact information: Architects, Engineers, Planners, Project Managers. T 905 984 8676. 89 - 91 St. Paul Street, Suite 100, St. Catharines, ON, L2R 3M3. www.quartekgroup.com

project title: YORK ROAD RESIDENTIAL INFILL
1317 YORK ROAD, NIAGARA-ON-THE-LAKE

drawing title: CONCEPTUAL SITE SERVICING

drawn by: TC, designed by: TC
scale: 1:200, date: 10 JULY 2025
job number: 24086, issue: B
drawing number: 24086-CSS

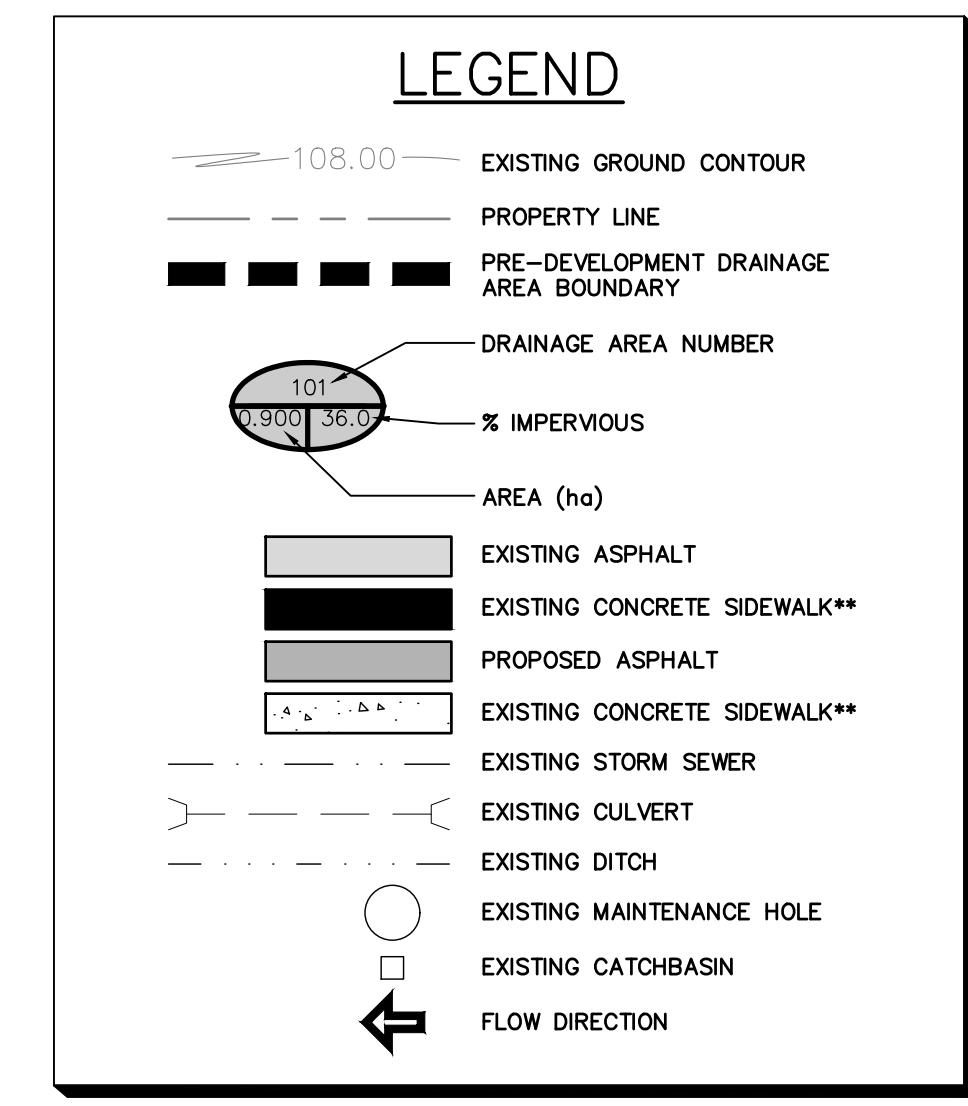
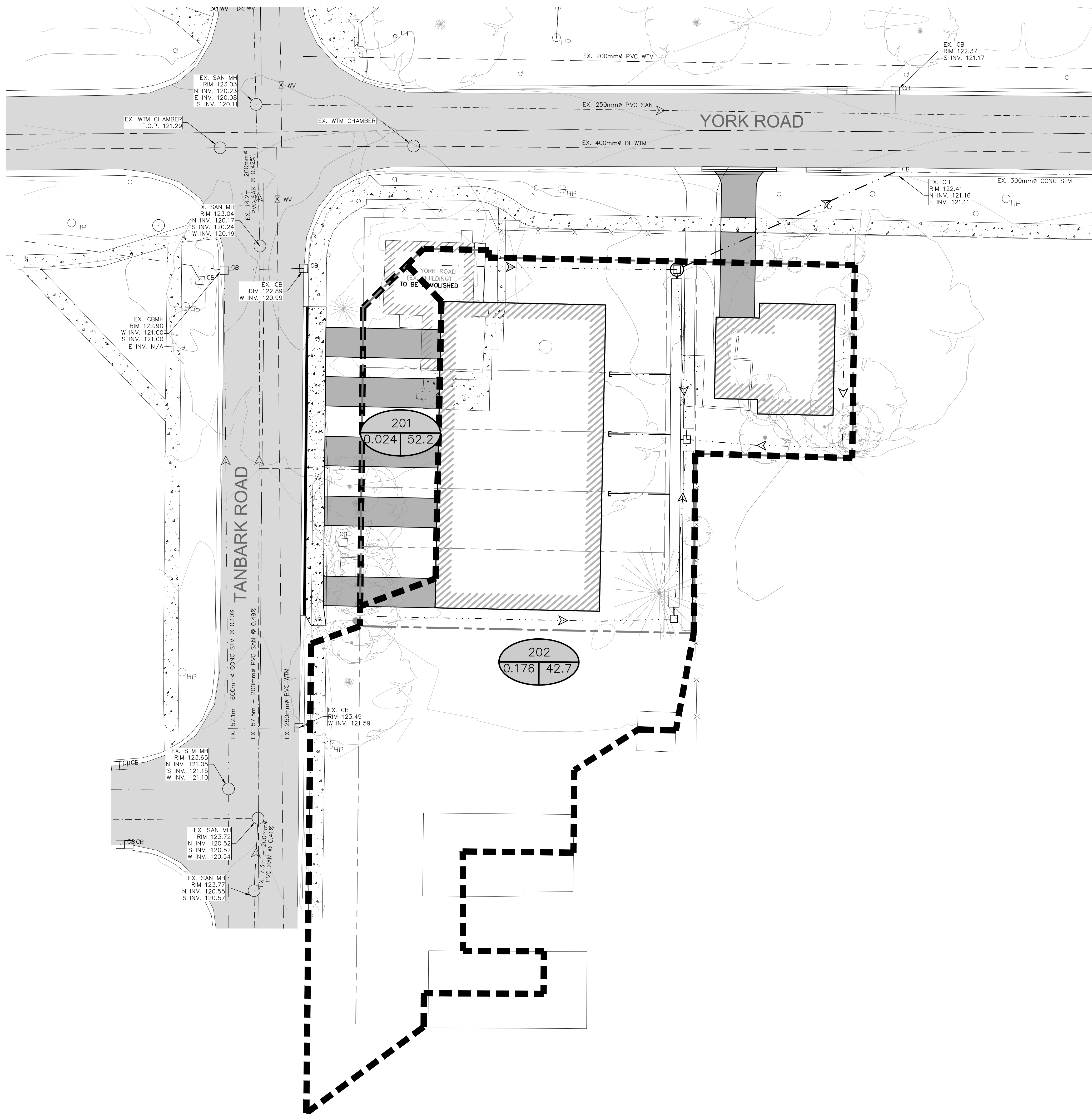

03 Mar 2026
PRELIMINARY

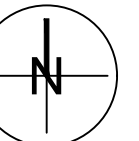

issue	issued for	date	int.
A	OPAZBA RESUBMISSION	03 MAR 2026	TC

seal

Do not scale drawings. Report any discrepancies to Quartek Group Inc. before proceeding.

Drawings must be sealed by the Architect and / or Engineer prior to the use for any building permit applications and / or government approval. Seals must be signed by the Architect and / or Engineer before drawings are used for any construction.

All construction to be in accordance with the current Ontario Building Code and all applicable Ontario regulations.

All drawings and related documents remain the property of Quartek Group Inc., all drawings are protected under copyright and under contract.

Quartek

- Architects
- Engineers
- Planners
- Project Managers

T 905 984 8676
 89 - 91 St. Paul Street, Suite 100,
 St. Catharines, ON, L2R 3M3
 www.quartekgroup.com

project title

YORK ROAD RESIDENTIAL INFILL

1317 YORK ROAD, NIAGARA-ON-THE-LAKE

drawing title

POST-DEVELOPMENT STORM DRAINAGE AREAS

drawn by: TC
 designed by: TC

scale: 1:200
 date: 03 MAR 2026

job number: 24086
 issue: A

drawing number: 24086-STM-2

STORMWATER MANAGEMENT REPORT

**YORK ROAD RESIDENTIAL INFILL
1317 York Road
Niagara-on-the-Lake, ON**

APPENDIX A

MIDUSS MODEL OUTPUT

5-yr Pre-Development

```
"          MIDUSS Output ----->"
"          MIDUSS version                      Version 2.25  rev. 465"
"          MIDUSS created                      February 5, 2008"
"          10  Units used:                      ie METRIC"
"          Job folder:                        P:\2024 Projects\24086 1317 York Rd NOTL\
"                                           Design\Preliminary\MIDUSS"
"          Output filename:                    5yr-Pre-RevC.out"
"          Licensee name:                      Quartek"
"          Company                            "
"          Date & Time last used:              2026-02-11 at 3:40:21 PM"
" 31      TIME PARAMETERS"
"          5.000  Time Step"
"          180.000 Max. Storm length"
"          1500.000 Max. Hydrograph"
" 32      STORM Chicago storm"
"          1  Chicago storm"
"          664.000 Coefficient A"
"          4.700  Constant B"
"          0.744  Exponent C"
"          0.375  Fraction R"
"          180.000 Duration"
"          1.000  Time step multiplier"
"          Maximum intensity                    120.814  mm/hr"
"          Total depth                          41.024  mm"
"          6  005hyd  Hydrograph extension used in this file"
" 33      CATCHMENT 101"
"          1  Triangular SCS"
"          1  Equal length"
"          1  SCS method"
"          101 DRAINS TO TANBARK 600MM  STM"
"          28.600 % Impervious"
"          0.040  Total Area"
"          6.200  Flow length"
"          2.000  Overland Slope"
"          0.029  Pervious Area"
"          6.200  Pervious length"
"          2.000  Pervious slope"
"          0.011  Impervious Area"
"          6.200  Impervious length"
"          2.000  Impervious slope"
"          0.250  Pervious Manning 'n'"
"          75.000 Pervious SCS Curve No."
"          0.219  Pervious Runoff coefficient"
"          0.100  Pervious Ia/S coefficient"
"          8.467  Pervious Initial abstraction"
"          0.015  Impervious Manning 'n'"
"          98.000 Impervious SCS Curve No."
"          0.838  Impervious Runoff coefficient"
"          0.100  Impervious Ia/S coefficient"
"          0.518  Impervious Initial abstraction"
```

	0.003	0.000	0.000	0.000	c.m/sec"
"	Catchment 101	Pervious	Impervious	Total Area	"
"	Surface Area	0.029	0.011	0.040	hectare"
"	Time of concentration	9.176	0.821	4.121	minutes"
"	Time to Centroid	113.137	87.511	97.632	minutes"
"	Rainfall depth	41.024	41.024	41.024	mm"
"	Rainfall volume	11.72	4.69	16.41	c.m"
"	Rainfall losses	32.033	6.639	24.771	mm"
"	Runoff depth	8.991	34.385	16.253	mm"
"	Runoff volume	2.57	3.93	6.50	c.m"
"	Runoff coefficient	0.219	0.838	0.396	"
"	Maximum flow	0.001	0.003	0.003	c.m/sec"

" 40 HYDROGRAPH Add Runoff "

"	4	Add Runoff "			
"		0.003	0.003	0.000	0.000"

" 40 HYDROGRAPH Start - New Tributary"

"	2	Start - New Tributary"			
"		0.003	0.000	0.000	0.000"

" 33 CATCHMENT 102"

"	1	Triangular SCS"			
"	1	Equal length"			
"	1	SCS method"			
"	102	DRAINS TO YORK 300MM STM"			
"	13.400	% Impervious"			
"	0.222	Total Area"			
"	20.200	Flow length"			
"	2.000	Overland Slope"			
"	0.192	Pervious Area"			
"	20.200	Pervious length"			
"	2.000	Pervious slope"			
"	0.030	Impervious Area"			
"	20.200	Impervious length"			
"	2.000	Impervious slope"			
"	0.250	Pervious Manning 'n'"			
"	75.000	Pervious SCS Curve No."			
"	0.220	Pervious Runoff coefficient"			
"	0.100	Pervious Ia/S coefficient"			
"	8.467	Pervious Initial abstraction"			
"	0.015	Impervious Manning 'n'"			
"	98.000	Impervious SCS Curve No."			
"	0.862	Impervious Runoff coefficient"			
"	0.100	Impervious Ia/S coefficient"			
"	0.518	Impervious Initial abstraction"			

	0.008	0.000	0.000	0.000	c.m/sec"
--	-------	-------	-------	-------	----------

"	Catchment 102	Pervious	Impervious	Total Area	"
"	Surface Area	0.192	0.030	0.222	hectare"
"	Time of concentration	18.639	1.668	12.236	minutes"
"	Time to Centroid	124.400	88.494	110.852	minutes"
"	Rainfall depth	41.024	41.024	41.024	mm"
"	Rainfall volume	78.87	12.20	91.07	c.m"

"	Rainfall losses	31.992	5.652	28.462	mm"
"	Runoff depth	9.032	35.372	12.562	mm"
"	Runoff volume	17.36	10.52	27.89	c.m"
"	Runoff coefficient	0.220	0.862	0.306	"
"	Maximum flow	0.005	0.007	0.008	c.m/sec"
" 40	HYDROGRAPH Add Runoff "				
"	4 Add Runoff "				
"		0.008	0.008	0.000	0.000"
" 38	START/RE-START TOTALS 102"				
"	3 Runoff Totals on EXIT"				
"	Total Catchment area			0.262	hectare"
"	Total Impervious area			0.041	hectare"
"	Total % impervious			15.721"	
" 19	EXIT"				

5-yr Post-Development

```
"          MIDUSS Output ----->"
"          MIDUSS version                      Version 2.25  rev. 465"
"          MIDUSS created                      February 5, 2008"
"          10  Units used:                      ie METRIC"
"          Job folder:                         P:\2024 Projects\24086 1317 York Rd NOTL\
"                                               Design\Preliminary\MIDUSS"
"          Output filename:                    5yr-Post-RevB.out"
"          Licensee name:                      Quartek"
"          Company                             "
"          Date & Time last used:              2026-02-27 at 4:06:00 PM"
" 31      TIME PARAMETERS"
"          5.000  Time Step"
"          180.000 Max. Storm length"
"          1500.000 Max. Hydrograph"
" 32      STORM Chicago storm"
"          1  Chicago storm"
"          664.000 Coefficient A"
"          4.700  Constant B"
"          0.744  Exponent C"
"          0.375  Fraction R"
"          180.000 Duration"
"          1.000  Time step multiplier"
"          Maximum intensity                    120.814  mm/hr"
"          Total depth                          41.024  mm"
"          6  005hyd  Hydrograph extension used in this file"
" 33      CATCHMENT 201"
"          1  Triangular SCS"
"          1  Equal length"
"          1  SCS method"
"          201  No description"
"          52.200 % Impervious"
"          0.024  Total Area"
"          3.700  Flow length"
"          2.000  Overland Slope"
"          0.011  Pervious Area"
"          3.700  Pervious length"
"          2.000  Pervious slope"
"          0.013  Impervious Area"
"          3.700  Impervious length"
"          2.000  Impervious slope"
"          0.250  Pervious Manning 'n'"
"          75.000  Pervious SCS Curve No."
"          0.218  Pervious Runoff coefficient"
"          0.100  Pervious Ia/S coefficient"
"          8.467  Pervious Initial abstraction"
"          0.015  Impervious Manning 'n'"
"          98.000  Impervious SCS Curve No."
"          0.814  Impervious Runoff coefficient"
"          0.100  Impervious Ia/S coefficient"
"          0.518  Impervious Initial abstraction"
```

	0.003	0.000	0.000	0.000	c.m/sec"
"	Catchment 201	Pervious	Impervious	Total Area	"
"	Surface Area	0.011	0.013	0.024	hectare"
"	Time of concentration	6.732	0.603	1.810	minutes"
"	Time to Centroid	110.378	87.659	92.134	minutes"
"	Rainfall depth	41.024	41.024	41.024	mm"
"	Rainfall volume	4.71	5.14	9.85	c.m"
"	Rainfall losses	32.079	7.626	19.315	mm"
"	Runoff depth	8.945	33.398	21.709	mm"
"	Runoff volume	1.03	4.18	5.21	c.m"
"	Runoff coefficient	0.218	0.814	0.529	"
"	Maximum flow	0.000	0.003	0.003	c.m/sec"

" 40 HYDROGRAPH Add Runoff "

"	4	Add Runoff "			
"		0.003	0.003	0.000	0.000"

" 40 HYDROGRAPH Start - New Tributary"

"	2	Start - New Tributary"			
"		0.003	0.000	0.000	0.000"

" 33 CATCHMENT 202"

"	1	Triangular SCS"			
"	1	Equal length"			
"	1	SCS method"			
"	202	No description"			
"	37.100	% Impervious"			
"	0.237	Total Area"			
"	19.700	Flow length"			
"	2.000	Overland Slope"			
"	0.149	Pervious Area"			
"	19.700	Pervious length"			
"	2.000	Pervious slope"			
"	0.088	Impervious Area"			
"	19.700	Impervious length"			
"	2.000	Impervious slope"			
"	0.250	Pervious Manning 'n'"			
"	75.000	Pervious SCS Curve No."			
"	0.220	Pervious Runoff coefficient"			
"	0.100	Pervious Ia/S coefficient"			
"	8.467	Pervious Initial abstraction"			
"	0.015	Impervious Manning 'n'"			
"	98.000	Impervious SCS Curve No."			
"	0.862	Impervious Runoff coefficient"			
"	0.100	Impervious Ia/S coefficient"			
"	0.518	Impervious Initial abstraction"			

"		0.022	0.000	0.000	0.000 c.m/sec"
---	--	-------	-------	-------	----------------

"	Catchment 202	Pervious	Impervious	Total Area	"
"	Surface Area	0.149	0.088	0.237	hectare"
"	Time of concentration	18.361	1.644	6.695	minutes"
"	Time to Centroid	124.065	88.473	99.227	minutes"
"	Rainfall depth	41.024	41.024	41.024	mm"
"	Rainfall volume	61.16	36.07	97.23	c.m"

```

"          Rainfall losses          31.993      5.661      22.224      mm"
"          Runoff depth              9.031      35.363     18.800      mm"
"          Runoff volume             13.46      31.09      44.56      c.m"
"          Runoff coefficient         0.220      0.862      0.458      "
"          Maximum flow              0.004      0.022      0.022      c.m/sec"
" 40      HYDROGRAPH Add Runoff "
"          4  Add Runoff "
"                0.022      0.022      0.000      0.000"
" 54      POND DESIGN"
"          0.022  Current peak flow    c.m/sec"
"          0.008  Target outflow    c.m/sec"
"          44.6   Hydrograph volume    c.m"
"          21.   Number of stages"
"          0.000  Minimum water level  metre"
"          0.900  Maximum water level  metre"
"          0.000  Starting water level  metre"
"          0     Keep Design Data: 1 = True; 0 = False"
"                Level Discharge      Volume"
"                0.000      0.000      0.000"
"                0.04500    0.00200    0.7849"
"                0.09000    0.00290    2.185"
"                0.1350    0.00350    3.949"
"                0.1800    0.00410    5.978"
"                0.2250    0.00460    8.209"
"                0.2700    0.00500    10.594"
"                0.3150    0.00540    13.097"
"                0.3600    0.00580    15.684"
"                0.4050    0.00610    18.325"
"                0.4500    0.00650    20.994"
"                0.4950    0.00680    23.662"
"                0.5400    0.00710    26.304"
"                0.5850    0.00740    28.891"
"                0.6300    0.00770    31.393"
"                0.6750    0.00800    33.779"
"                0.7200    0.00820    36.009"
"                0.7650    0.00850    38.038"
"                0.8100    0.00870    39.802"
"                0.8550    0.00900    41.203"
"                0.9000    0.00920    41.987"
"          1.  SUPERPIPES_1"
"          1.  Type 1 is Pipe"
"                Downstream      Pipe      Pipe      Pipe      Pipe Number of"
"                Invert      Length      Width      Height      Grade %      Pipes"
"                0.000      6.000      0.900      0.900      0.000      11.000"
"                Peak outflow          0.006      c.m/sec"
"                Maximum level          0.360      metre"
"                Maximum storage          15.682      c.m"
"                Centroidal lag          2.182      hours"
"                0.022      0.022      0.006      0.000 c.m/sec"
" 40      HYDROGRAPH Next link "

```

```

"          5  Next link "
"              0.022      0.006      0.006      0.000"
" 51      PIPE DESIGN"
"      0.006  Current peak flow      c.m/sec"
"      0.013  Manning 'n'"
"      0.200  Diameter      metre"
"      0.500  Gradient      %"
"          Depth of flow              0.068      metre"
"          Velocity                    0.614      m/sec"
"          Pipe capacity                0.023      c.m/sec"
"          Critical depth                0.064      metre"
" 53      ROUTE      Pipe Route 24"
"      24.00      Pipe Route 24 Reach length      ( metre)"
"      0.344  X-factor <= 0.5"
"      29.330  K-lag      ( seconds)"
"      0.000  Default(0) or user spec.(1) values used"
"      0.500  X-factor <= 0.5"
"      30.000  K-lag      ( seconds)"
"      0.500  Beta weighting factor"
"      37.500  Routing time step      ( seconds)"
"          1  No. of sub-reaches"
"          Peak outflow                  0.006      c.m/sec"
"              0.022      0.006      0.006      0.000 c.m/sec"
" 38      START/RE-START TOTALS 202"
"          3  Runoff Totals on EXIT"
"          Total Catchment area              0.261      hectare"
"          Total Impervious area              0.100      hectare"
"          Total % impervious                38.489"
" 38      START/RE-START TOTALS 202"
"          3  Runoff Totals on EXIT"
"          Total Catchment area              0.261      hectare"
"          Total Impervious area              0.100      hectare"
"          Total % impervious                38.489"
" 19      EXIT"

```

100-yr Post-Development

```
"          MIDUSS Output ----->"
"          MIDUSS version                      Version 2.25  rev. 465"
"          MIDUSS created                      February 5, 2008"
"          10  Units used:                      ie METRIC"
"          Job folder:                        P:\2024 Projects\24086 1317 York Rd NOTL\
"                                               Design\Preliminary\MIDUSS\SS"
"          Output filename:                    100yr-Post-Rev_E.out"
"          Licensee name:                      Quartek"
"          Company                            Quartek_2"
"          Date & Time last used:              2026-02-26 at 1:21:38 PM"
" 31      TIME PARAMETERS"
"          5.000  Time Step"
"          180.000 Max. Storm length"
"          1500.000 Max. Hydrograph"
" 32      STORM Chicago storm"
"          1  Chicago storm"
"          980.000 Coefficient A"
"          3.700  Constant B"
"          0.732  Exponent C"
"          0.375  Fraction R"
"          180.000 Duration"
"          1.000  Time step multiplier"
"          Maximum intensity                    198.433  mm/hr"
"          Total depth                          64.717  mm"
"          6  100hyd  Hydrograph extension used in this file"
" 33      CATCHMENT 201"
"          1  Triangular SCS"
"          1  Equal length"
"          1  SCS method"
"          201  No description"
"          52.200 % Impervious"
"          0.024  Total Area"
"          3.700  Flow length"
"          2.000  Overland Slope"
"          0.011  Pervious Area"
"          3.700  Pervious length"
"          2.000  Pervious slope"
"          0.013  Impervious Area"
"          3.700  Impervious length"
"          2.000  Impervious slope"
"          0.250  Pervious Manning 'n'"
"          75.000  Pervious SCS Curve No."
"          0.343  Pervious Runoff coefficient"
"          0.100  Pervious Ia/S coefficient"
"          8.467  Pervious Initial abstraction"
"          0.015  Impervious Manning 'n'"
"          98.000  Impervious SCS Curve No."
"          0.836  Impervious Runoff coefficient"
"          0.100  Impervious Ia/S coefficient"
"          0.518  Impervious Initial abstraction"
```

"		0.007	0.000	0.000	0.000	c.m/sec"
"	Catchment 201		Pervious	Impervious	Total Area	"
"	Surface Area	0.011	0.013	0.024		hectare"
"	Time of concentration	4.219	0.487	1.507		minutes"
"	Time to Centroid	104.043	86.259	91.120		minutes"
"	Rainfall depth	64.717	64.717	64.717		mm"
"	Rainfall volume	7.42	8.11	15.53		c.m"
"	Rainfall losses	42.494	10.624	25.858		mm"
"	Runoff depth	22.223	54.093	38.859		mm"
"	Runoff volume	2.55	6.78	9.33		c.m"
"	Runoff coefficient	0.343	0.836	0.600		"
"	Maximum flow	0.001	0.006	0.007		c.m/sec"
" 40	HYDROGRAPH Add Runoff "					
"	4	Add Runoff "				
"		0.007	0.007	0.000	0.000	"
" 40	HYDROGRAPH Start - New Tributary"					
"	2	Start - New Tributary"				
"		0.007	0.000	0.000	0.000	"
" 33	CATCHMENT 202"					
"	1	Triangular SCS"				
"	1	Equal length"				
"	1	SCS method"				
"	202	No description"				
"	37.100	% Impervious"				
"	0.237	Total Area"				
"	19.700	Flow length"				
"	2.000	Overland Slope"				
"	0.149	Pervious Area"				
"	19.700	Pervious length"				
"	2.000	Pervious slope"				
"	0.088	Impervious Area"				
"	19.700	Impervious length"				
"	2.000	Impervious slope"				
"	0.250	Pervious Manning 'n'"				
"	75.000	Pervious SCS Curve No."				
"	0.346	Pervious Runoff coefficient"				
"	0.100	Pervious Ia/S coefficient"				
"	8.467	Pervious Initial abstraction"				
"	0.015	Impervious Manning 'n'"				
"	98.000	Impervious SCS Curve No."				
"	0.899	Impervious Runoff coefficient"				
"	0.100	Impervious Ia/S coefficient"				
"	0.518	Impervious Initial abstraction"				
"		0.041	0.000	0.000	0.000	c.m/sec"
"	Catchment 202		Pervious	Impervious	Total Area	"
"	Surface Area	0.149	0.088	0.237		hectare"
"	Time of concentration	11.508	1.328	5.350		minutes"
"	Time to Centroid	113.541	86.816	97.376		minutes"
"	Rainfall depth	64.717	64.717	64.717		mm"
"	Rainfall volume	96.48	56.90	153.38		c.m"

```

"          Rainfall losses          42.301      6.539      29.033      mm"
"          Runoff depth              22.416      58.178     35.684      mm"
"          Runoff volume             33.42       51.15      84.57       c.m"
"          Runoff coefficient         0.346       0.899      0.551       "
"          Maximum flow              0.013       0.038      0.041       c.m/sec"
" 40      HYDROGRAPH Add Runoff "
"          4      Add Runoff "
"                  0.041      0.041      0.000      0.000"
" 54      POND DESIGN"
"          0.041      Current peak flow      c.m/sec"
"          0.008      Target outflow      c.m/sec"
"          84.6      Hydrograph volume      c.m"
"          21.      Number of stages"
"          0.000      Minimum water level      metre"
"          0.900      Maximum water level      metre"
"          0.000      Starting water level      metre"
"          0      Keep Design Data: 1 = True; 0 = False"
"                  Level Discharge      Volume"
"                  0.000      0.000      0.000"
"                  0.04500      0.00200      0.7089"
"                  0.09000      0.00290      2.079"
"                  0.1350      0.00350      3.823"
"                  0.1800      0.00410      5.836"
"                  0.2250      0.00460      8.055"
"                  0.2700      0.00500      10.431"
"                  0.3150      0.00540      12.927"
"                  0.3600      0.00580      15.509"
"                  0.4050      0.00610      18.148"
"                  0.4500      0.00650      20.815"
"                  0.4950      0.00680      23.485"
"                  0.5400      0.00710      26.129"
"                  0.5850      0.00740      28.720"
"                  0.6300      0.00770      31.230"
"                  0.6750      0.00800      33.624"
"                  0.7200      0.00820      35.866"
"                  0.7650      0.00850      37.910"
"                  0.8100      0.00870      39.694"
"                  0.8550      0.00900      41.123"
"                  0.9000      0.00920      41.972"
"          1.      SUPERPIPES_1"
"          1.      Type 1 is Pipe"
"                  Downstream      Pipe      Pipe      Pipe      Pipe Number of"
"                  Invert      Length      Width      Height      Grade %      Pipes"
"                  0.000      6.000      0.900      0.900      0.000      11.000"
"          Peak outflow              0.008      c.m/sec"
"          Maximum level              0.755      metre"
"          Maximum storage            37.456      c.m"
"          Centroidal lag              2.532      hours"
"          0.041      0.041      0.008      0.000 c.m/sec"
" 40      HYDROGRAPH Next link "

```

```

"          5  Next link "
"              0.041      0.008      0.008      0.000"
" 51      PIPE DESIGN"
"      0.008  Current peak flow      c.m/sec"
"      0.013  Manning 'n'"
"      0.200  Diameter      metre"
"      0.500  Gradient      %"
"          Depth of flow              0.083      metre"
"          Velocity                    0.680      m/sec"
"          Pipe capacity                0.023      c.m/sec"
"          Critical depth                0.077      metre"
" 53      ROUTE      Pipe Route 24"
"      24.00      Pipe Route 24 Reach length      ( metre)"
"      0.304  X-factor <= 0.5"
"      26.481  K-lag      ( seconds)"
"      0.000  Default(0) or user spec.(1) values used"
"      0.500  X-factor <= 0.5"
"      30.000  K-lag      ( seconds)"
"      0.500  Beta weighting factor"
"      33.333  Routing time step      ( seconds)"
"          1  No. of sub-reaches"
"          Peak outflow                  0.008      c.m/sec"
"              0.041      0.008      0.008      0.000 c.m/sec"
" 38      START/RE-START TOTALS 202"
"          3  Runoff Totals on EXIT"
"          Total Catchment area              0.261      hectare"
"          Total Impervious area              0.100      hectare"
"          Total % impervious                38.489"
" 19      EXIT"

```

STORMWATER MANAGEMENT REPORT

**YORK ROAD RESIDENTIAL INFILL
1317 York Road
Niagara-on-the-Lake, ON**

APPENDIX B

Solflo Max Data Sheet

DATA SHEET

SOLFLO MAX

PRODUCT DESCRIPTION : Rigid dual wall pipe, with smooth interior and corrugated exterior walls for roadway use.

FUNCTION : Non-perforated pipe: Gravity flow of water in networks and water course piping.
Perforated pipe: Used to collect surface runoff and control the ground water level.

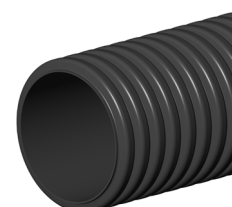

MANUFACTURING STANDARDS : BNQ 3624-120, CSA B182.8, ASTM 2648, ASTM 2306 or AASHTO M294

RAW MATERIAL : Made from HDPE resin that complies with properties classification of ASTM D3350 standard.

TECHNICAL DATA : Structural strength: CAN/CSA S6 (CL-625), AASHTO (HS20 and HS25) and AREMA Cooper (E-80)
Filter: Needle punched nonwoven geotextile Rutex IV with 110-micron openings

TECHNICAL DATA

Diameter						Manning	Category ¹		Minimum backfill				Maximum backfill							
Nominal		Interior		Outside			Class A	Class B	Weight ³		CL-625		E-80		CL-625		E-80			
mm	in	mm	in	mm	in				n	kg/m	lb/ft	CL-625	E-80	CL-625	E-80	Class A	Class B	Class A		
100	4	101	4,0	120	4,7	0,010	R320	1,0	0,6	0,3	1,0	0,6	2,0	20,0	65,6	8,5	27,9			
150	6	150	5,9	176	6,9	0,010	R320	2,0	1,4	0,3	1,0	0,6	2,0	19,0	62,3	8,5	27,9			
200	8	205	8,1	236	9,3	0,010	R320	2,7	1,8	0,3	1,0	0,6	2,0	18,0	59,1	7,9	25,9			
250	10	251	9,9	297	11,7	0,010	R320	4,0	2,7	0,3	1,0	0,6	2,0	18,0	59,1	7,9	25,9			
300	12	303	11,9	363	14,3	0,010	R320	R210	5,4	3,6	0,3	1,0	0,6	2,0	17,0	55,8	16,0	52,5	8,5	27,9
375	15	381	15,0	449	17,7	0,010	R320	R210	7,9	5,3	0,3	1,0	0,6	2,0	17,0	55,8	17,0	55,8	8,8	28,9
450	18	457	18,0	544	21,4	0,010	R320	R210	11,7	7,8	0,3	1,0	0,6	2,0	17,0	55,8	17,0	55,8	7,9	25,9
525	21	535	21,1	640	25,2	0,012	R320	R210	16,2	10,9	0,3	1,0	0,6	2,0	16,0	52,5	16,0	52,5	7,6	24,9
600	24	603	23,7	741	29,2	0,012	R320	R210	19,5	13,1	0,3	1,0	0,6	2,0	15,0	49,2	15,0	49,2	7,3	24,0
750	30	756	29,8	890	35,0	0,012	R320	R210	32,8	22,0	0,3	1,0	0,6	2,0	15,0	49,2	13,0	42,7	6,1	20,0
900	36	900	35,4	1041	41,0	0,012	R320	R210	51,8	34,8	0,3	1,0	0,9	3,0	15,0	49,2	13,0	42,7	6,7	22,0
1050	42	1067	42,0	1224	48,2	0,012	R140		43,5	29,2	0,3	1,0	1,2	3,9	13,0	42,7			6,7	22,0
1200	48	1220	48,0	1377	54,2	0,012	R125		53,0	35,6	0,3	1,0	1,2	3,9	13,0	42,7			5,8	19,0
1500	60	1514	59,6	1701	67,0	0,012	R95 ²		70,7	47,5	0,5	1,6	1,2	3,9	11,0	36,1			6,4	21,0

Note 1: For reference, a Class A category pipe will have a minimum compression stiffness of 320 kPa at 5% deformation.

Note 2: R95 refers to the categorization of BNQ 3624-120 and CSA B182.8 standards.

Note 3: Values in the table are for Class A pipe.

Note 4: Values in the table are approximate and may change without notice.

Note 5: 100 mm (4 in) to 1500 mm (60 in) pipes are certified BNQ 3624-120 and CSA B182.8 standards. AASHTO M294 certified pipes are available upon request. Please contact your Soleno representative for more information.

DATA SHEET

SOLFLO MAX (CONT'D)

LENGTHS TABLE - CLASS A according to available couplers

Nominal Diameter		No coupler		Soil tight couplers						Watertight couplers					
		Plain		BC		DBS		SC		BIGC ¹		BG		DBIG ¹	
mm	in	m	ft	m	ft	m	ft	m	ft	m	ft	m	ft	m	ft
100	4	6	19,7			6	19,7	6	19,7					4/6	13,1/19,7
150	6	6	19,7			6	19,7	6	19,7					4/6	13,1/19,7
200	8	6	19,7			6	19,7	6	19,7					4/6	13,1/19,7
250	10	6	19,7			6	19,7	6	19,7					4/6	13,1/19,7
300	12	6/9	19,7/29,5	6	19,7			6/9	19,7/29,5	4/6	13,1/19,7				
375	15	6/9	19,7/29,5	6	19,7			6/9	19,7/29,5	4/6	13,1/19,7				
450	18	6/9	19,7/29,5	6	19,7			6/9	19,7/29,5	4/6	13,1/19,7				
525	21	6/9	19,7/29,5	6	19,7			6/9	19,7/29,5	4/6	13,1/19,7				
600	24	6/9	19,7/29,5	6	19,7			6/9	19,7/29,5	4/6	13,1/19,7				
750	30	6/9	19,7/29,5	6	19,7			6/9	19,7/29,5	4/6	13,1/19,7				
900	36	6/9	19,7/29,5	6	19,7			6/9	19,7/29,5	4/6	13,1/19,7				
1 050	42							coupler available ²				3,3	10,8		
1 200	48	6/9	19,7/29,5	6	19,7			6/9	19,7/29,5	4/6	13,1/19,7				
1 500	60											6	19,7		

Note 1: BIGC and DBIG connectors are available for non-perforated pipe only.

Note 2: The split coupler is available, although the 1050 mm (42 in) pipe is only available with BG type coupler.

Note 3: Values in the table are approximate and may change without notice.

Note 4: Lengths in the table have a tolerance between -1 % to 3 %.

LENGTHS TABLE - CLASS B according to available couplers

Nominal Diameter		No coupler		Soil tight couplers					
		Plain		BC		SC			
mm	in	m	ft	m	ft	m	ft		
300	12	6/9	19,7/29,5	6	19,7	6/9	19,7/29,5		
375	15	6/9	19,7/29,5	6	19,7	6/9	19,7/29,5		
450	18	6/9	19,7/29,5	6	19,7	6/9	19,7/29,5		
525	21	6/9	19,7/29,5	6	19,7	6/9	19,7/29,5		
600	24	6/9	19,7/29,5	6	19,7	6/9	19,7/29,5		
750	30	6/9	19,7/29,5	6	19,7	6/9	19,7/29,5		
900	36	6/9	19,7/29,5	6	19,7	6/9	19,7/29,5		

Note 1: Values in the table are approximate and may change without notice.

Note 2: Lengths in the table have a tolerance between -1 % to 3 %.

LEGEND

Plain : plain end
BC : bell with clips
DBS : double bell snap
SC : split couplers
BIGC : bell with integrated gasket
BG : o-ring bell gasket
DBIG : double bell with integrated gasket

APPLICATIONS : Driveway culvert, culvert, stormwater sewer, beaver barrier, ventilation, ditch piping, roadway drainage, drainage collector and outlet, detention or retention system and trench drain.

OPTIONS : Special lengths are available (upon request)
 Beveled cut
 Welded coupler for service entrance or connecting to cath basin
 Fish weir

INSTALLATION : Visit solen.com to consult the installation guide.

STORMWATER MANAGEMENT REPORT

**YORK ROAD RESIDENTIAL INFILL
1317 York Road
Niagara-on-the-Lake, ON**

APPENDIX C

Tempest Inlet Control Device Flow Chart (LMF-105)

Tempest Inlet Control Device Flow Chart

Chart 1: LMF 14 Preset Flow Curves

