

FIRELANE 13B SEPTIC SYSTEMS

CURRENT DWELLINGS	PROPOSED CONDO UNIT	
#2 Firelane 13B	1	Waterfront
#4 Firelane 13B	2	Waterfront
#6 Firelane 13B	3	Waterfront
#14 Firelane 13B	4	Waterfront
#15 Firelane13B	5	Inland
#13 Firelane 13B	6	Inland
#11 Firelane 13B	7	Inland
#9 Firelane 13B	8	Inland
#7 Firelane 13B	9	Inland
#3 Firelane 13B	10	Inland

AS EXISTING (2024)	
# BEDROOMS	L / DAY
2	1,100
1	750
2	1,100
2	1,100
1	750
2	1,100
2	1,100
2	1,100
2	1,100
1	750
17	9,950

PROPOSED CONDO *			
PROPOSED CONDO UNIT	PROPOSED # BEDROOMS	MIN L / DAY	PROPOSED SYSTEM
1	2	1,100	1,325
2	2	1,100	1,325
3	2	1,100	1,325
4	4	2,000	2,250
5	2	1,100	1,325
6	3	1,600	1,800
7	2	1,100	1,325
8	2	1,100	1,325
9	2	1,100	1,325
10	2	1,100	1,325
10	23	12,400	14,650

**Subject to change depending on desired construction*

Aug 8, 2023

CUSTOMER:

Dylan Earl
2 Firelane 13B
Niagara On The Lake, ON

CONTRACTOR:

6M Contracting Ltd
2239 Burger Rd.
Stevensville ON L0S 1S0
Tel/Fax: (905)382-6622
BCIN: 108377

SEPTIC INFORMATION:

Based ON: 2 bedroom Dwelling
> 200 m2 living space
> 20 fixture units
(up to 2.5 bathrooms)

SEPTIC BED: (sized to 1325 L/day)
- excavation into native sandy soil
- 13m2 Filter/Stone Bed (3.2m by 4.2m)
- 3" pipes - 4 runs, 10' long, 2' apart
- metal corner pegs
- filter cloth to cover stone bed
- backfilled with native sandy soil
- covered with topsoil and seeded.

SEPTIC TANK: Bionest Aeration Tank
- BTT1325 with Air pump, diffusers, &
ABS plastic bioreactor media.
- > 5' from Structure(s)
- > 50' from Cistern

END PROFILE:

3" perf tile embedded in 12" 3/4" Clear Stone

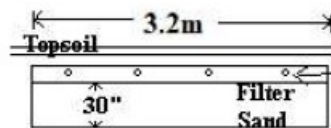

Native Sand (assumed) TTime 15min/cm



Aug 8, 2023

CUSTOMER:

Dylan Earl
4 firelane 13B
Niagara On The Lake, ON

CONTRACTOR:

6M Contracting Ltd
2239 Burger Rd.
Stevensville ON L0S 1S0
Tel/Fax: (905)382-6622
BCIN: 108377

SEPTIC INFORMATION:

Based ON: 2 bedroom Dwelling
> 200m² living space
> 20 fixture units
(up to 2.5 bathrooms)

SEPTIC BED: (sized to 1325L/day)
- excavation into native sandy soil
- 3 shallow buried trench laterals
- 10m Long each lateral- TOTAL 30m
- 3m from property lines and trees
- 5m from structures
- 2m separation between each lateral

SEPTIC TANK: Bionest Aeration Tank
- BTT1325 with Air pump, diffusers, &
ABS plastic bioreactor media.
-> 5' from Structure(s)
-> 50' from Cistern

END PROFILE:

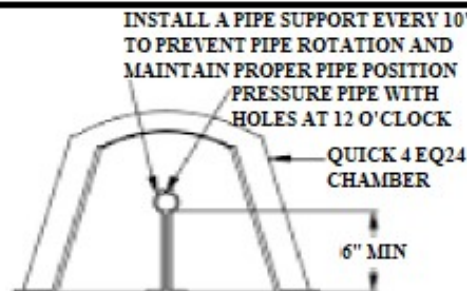

Aug 8, 2023

CUSTOMER:

Dylan Earl
6 Firelane 13B
Niagara On The Lake, ON

CONTRACTOR:

6M Contracting Ltd
2239 Burger Rd.
Stevensville ON L0S 1S0
Tel/Fax: (905)382-6622
BCIN: 108377

SEPTIC INFORMATION:

Based ON: 2 bedroom Dwelling
> 200m² living space
> 20 fixture units
(up to 2.5 bathrooms)

SEPTIC BED: (sized to 1325 L/day)
- excavation into native sandy soil
- 3 shallow buried trench laterals
- 10m Long each lateral- TOTAL 30m
- 3m from property lines and trees
- 5m from structures
- 2m separation between each lateral

SEPTIC TANK: Bionest Aeration Tank
- BTT1325 with Air pump, diffusers, &
ABS plastic bioreactor media.
- > 5' from Structure(s)
- > 50' from Cistern

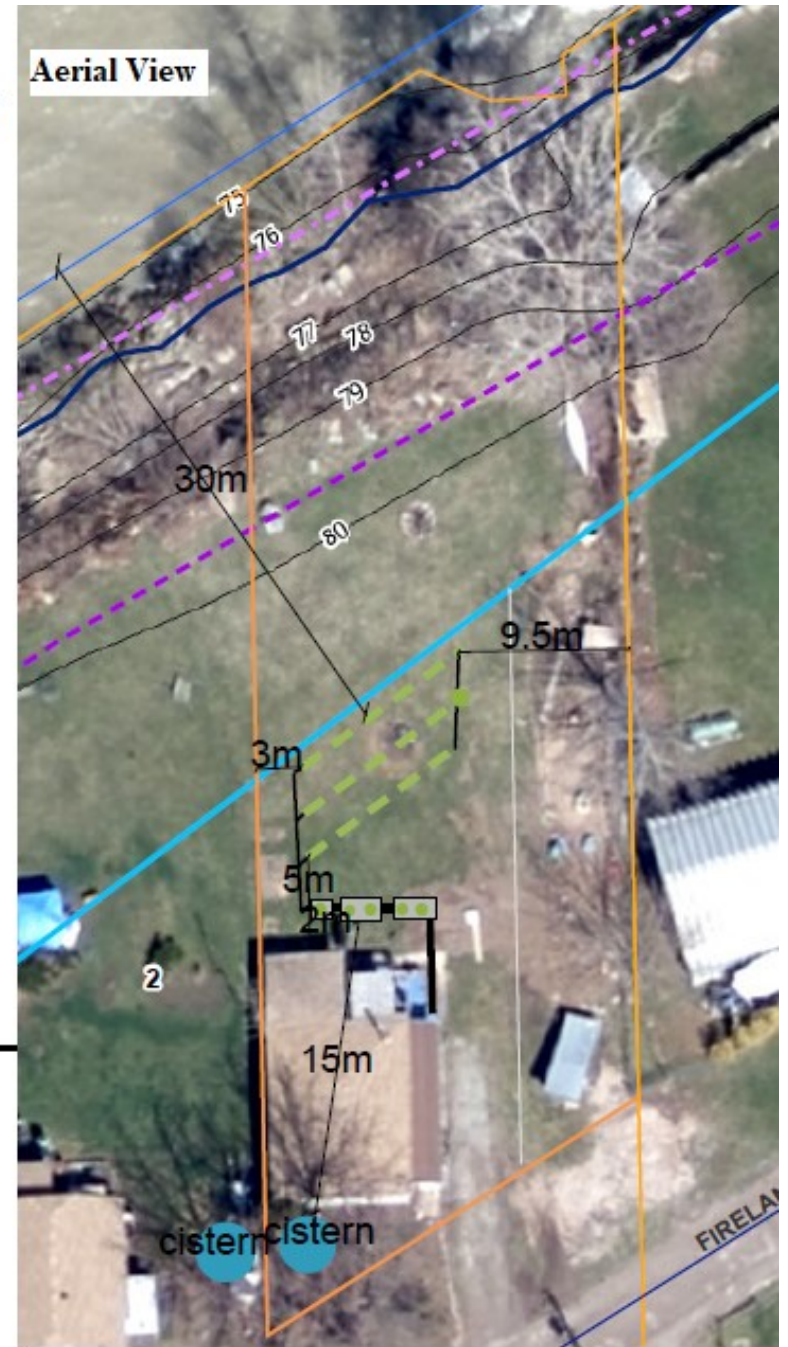

END PROFILE:

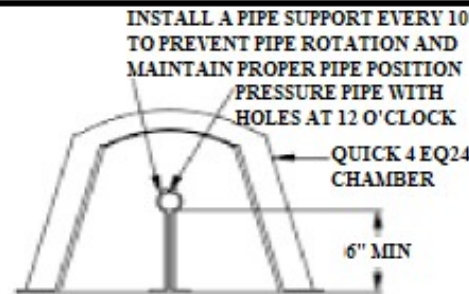

August 8, 2023

CUSTOMER:

Dylan Earl
14 Firelane 13B
Niagara On The Lake, ON

CONTRACTOR:

6M Contracting Ltd
2239 Burger Rd.
Stevensville ON L0S 1S0
Tel/Fax: (905)382- 6622
BCIN: 108377

SEPTIC INFORMATION:

Based ON: 4 bedroom Dwelling
>200m² living space
>20 fixture units
(up to 2.5 bathrooms)

SEPTIC BED: (sized for 2000L/day)
- excavation into native sandy soil
- 23 m² Filter/Stone Bed (4.6m by 5m)
- 3" pipes - 4 runs, 12' long, 45" apart
- metal corner pegs
- filter cloth to cover stone bed
- backfilled with native sandy soil
- covered with topsoil and seeded.

SEPTIC TANK: Bionest Aeration Tank
- BTT 2250 with Air pump, diffusers, &
ABS plastic bioreactor media.
- > 5' from Structure(s)
- > 50' from Cistern



AERIAL VIEW:



END PROFILE:

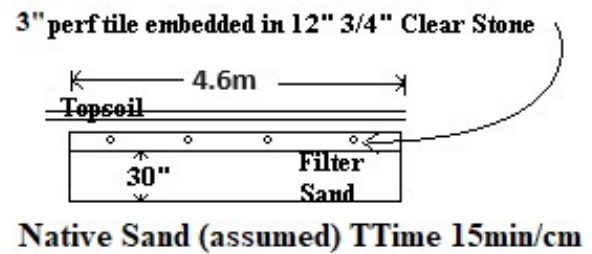

August 10, 2023

CUSTOMER:

Dylan Earl
15 Firelane 13B
Niagara On The Lake, ON

CONTRACTOR:

6M Contracting Ltd
2239 Burger Rd.
Stevensville ON L0S 1S0
Tel/Fax: (905)382- 6622
BCIN: 108377

SEPTIC INFORMATION:

Based ON: 2 bedroom Dwelling
>200m² Living Space
>20 fixture units
(up to 2.5 bathrooms)

SEPTIC BED: (sized for 1325 L/day)
- excavation into native sandy soil
-1 Shallow Buried Trench Lateral
- 10m Long Lateral
- 3m from Property Lines and Trees
- 5m from structures

SEPTIC TANK: Bionest Aeration Tank
- BTT 1325 with Air pump, diffusers, &
ABS plastic bioreactor media.
- > 5' from Structure(s)
- > 50' from Cistern

PUMP TANK: - 1000L Concrete
- 1/2 HP Pump

AERIAL VIEW:



END PROFILE:

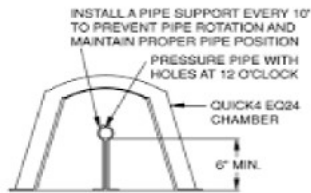

CUSTOMER:

Dylan Earl
13 Firelane 13B
Niagara On The Lake, ON

CONTRACTOR:

6M Contracting Ltd
2239 Burger Rd.
Stevensville ON L0S 1S0
Tel/Fax: (905)382- 6622
BCIN: 108377

SEPTIC INFORMATION:

Based ON: 3 bedroom Dwelling
> 200m² Living Space
>20 fixture units
(up to 2.5 bathrooms)

SEPTIC BED: (sized for 1800L/ Day)
- excavation into native sandy soil
- 4 Shallow Buried Trench Laterals
- 10m Long Each Lateral - TOTAL 40m
- 3m from Property Lines and Trees
- 5m from structures
- 2m separation between each lateral.

SEPTIC TANK: Bionest Aeration Tank
- BTT 1800 with Air pump, diffusers, & ABS plastic bioreactor media.
-> 5' from Structure(s)
-> 50' from Cistern

PUMP TANK: - 1000L Concrete
- 1/2 HP Pump



AERIAL VIEW:



END PROFILE:

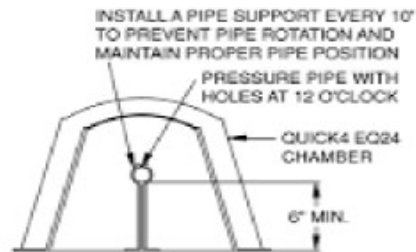

June 12, 2023

CUSTOMER:

Dylan Earl
11 Firelane 13B
Niagara On The Lake, ON

CONTRACTOR:

6M Contracting Ltd
2239 Burger Rd.
Stevensville ON L0S 1S0
Tel/Fax: (905)382- 6622
BCIN: 108377

SEPTIC INFORMATION:

Based ON: 2 bedroom Dwelling
>200m² living space
> 20 fixture units
(up to 2.5 bathrooms)

SEPTIC BED: (sized for 1325L/day)
- excavation into native sandy soil
- 3 Shallow Buried Trench Laterals
- 10m Long Each Lateral - TOTAL 30m
- 3m from Property Lines and Trees
- 5m from structures
- 2m separation between each lateral.

SEPTIC TANK: Bionest Aeration Tank
- BTT 1325 with Air pump, diffusers, &
ABS plastic bioreactor media.
- > 5' from Structure(s)
- > 50' from Cistern

PUMP TANK: - 1000L Concrete
- 1/2 HP Pump

AERIAL VIEW:



END PROFILE:

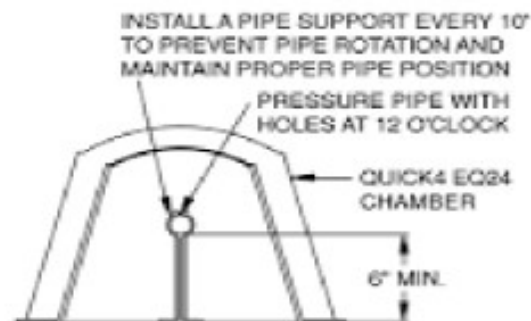

August 8, 2023

CUSTOMER:

Dylan Earl
9 Firelane 13B
Niagara On The Lake, ON

CONTRACTOR:

6M Contracting Ltd
2239 Burger Rd.
Stevensville ON L0S 1S0
Tel/Fax: (905)382- 6622
BCIN: 108377

SEPTIC INFORMATION:

Based ON: 2 bedroom Dwelling
>200m² living space
> 20 fixture units
(up to 2.5 bathrooms)

SEPTIC BED: (sized for 1325L/ day)
- excavation into native sandy soil
- 3 Shallow Buried Trench Laterals
- 10m Long Each Lateral - TOTAL 30m
-3m from Property Lines and Trees
- 5m from structures
- 2m separation between each lateral.

SEPTIC TANK: Bionest Aeration Tank
-BTT 1325 with Air pump, diffusers, &
ABS plastic bioreactor media.
-> 5' from Structure(s)
-> 50' from Cistern

PUMP TANK: - 1000L Concrete
- 1/2 HP Pump



AERIAL VIEW:



END PROFILE:

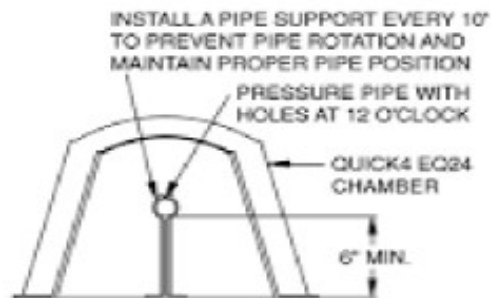

August 8, 2023

CUSTOMER:

Dylan Earl
7 Firelane 13B
Niagara On The Lake, ON

CONTRACTOR:

6M Contracting Ltd
2239 Burger Rd.
Stevensville ON L0S 1S0
Tel/Fax: (905)382-6622
BCIN: 108377

SEPTIC INFORMATION:

Based ON: 2 bedroom Dwelling
> 200m² living space
> 20 fixture units
(up to 2.5 bathrooms)

SEPTIC BED: (sized for 1325L/ day)
- excavation into native sandy soil
- 3 Shallow Buried Trench Laterals
- 10m Long Each Lateral - TOTAL 30m
- 3m from Property Lines and Trees
- 5m from structures
- 2m separation between each lateral.

SEPTIC TANK: Bionest Aeration Tank
- BTT 1325 with Air pump, diffusers, &
ABS plastic bioreactor media.
- > 5' from Structure(s)
- > 50' from Cistern

PUMP TANK: - 1000L Concrete
- 1/2 HP Pump



AERIAL VIEW:



END PROFILE:

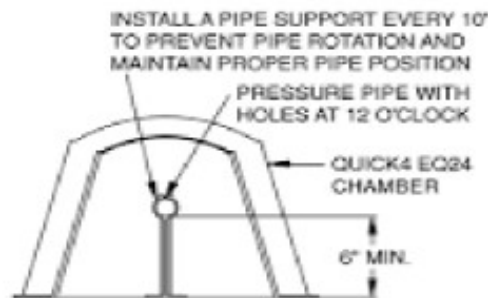

June 12, 2023

CUSTOMER:

Dylan Earl
3 Firelane 13B
Niagara On The Lake, ON

CONTRACTOR:

6M Contracting Ltd
2239 Burger Rd.
Stevensville ON L0S 1S0
Tel/Fax: (905)382-6622
BCIN: 108377

SEPTIC INFORMATION:

Based ON: 2 bedroom Dwelling
> 220m² living space
> 25 fixture units
(up to 3 bathrooms)

SEPTIC BED: (Sized for 1325L/ Day)
- excavation into native sandy soil
- 3 Shallow Buried Trench Laterals
- 10m Long Each Lateral - TOTAL 30m
- 3m from Property Lines and Trees
- 5m from structures
- 2m separation between each lateral.

SEPTIC TANK: Bionest Aeration Tank
- BTT 1325 with Air pump, diffusers, &
ABS plastic bioreactor media.
-> 5' from Structure(s)
-> 50' from Cistern

PUMP TANK: - 1000L Concrete
- 1/2 HP Pump



AERIAL VIEW:

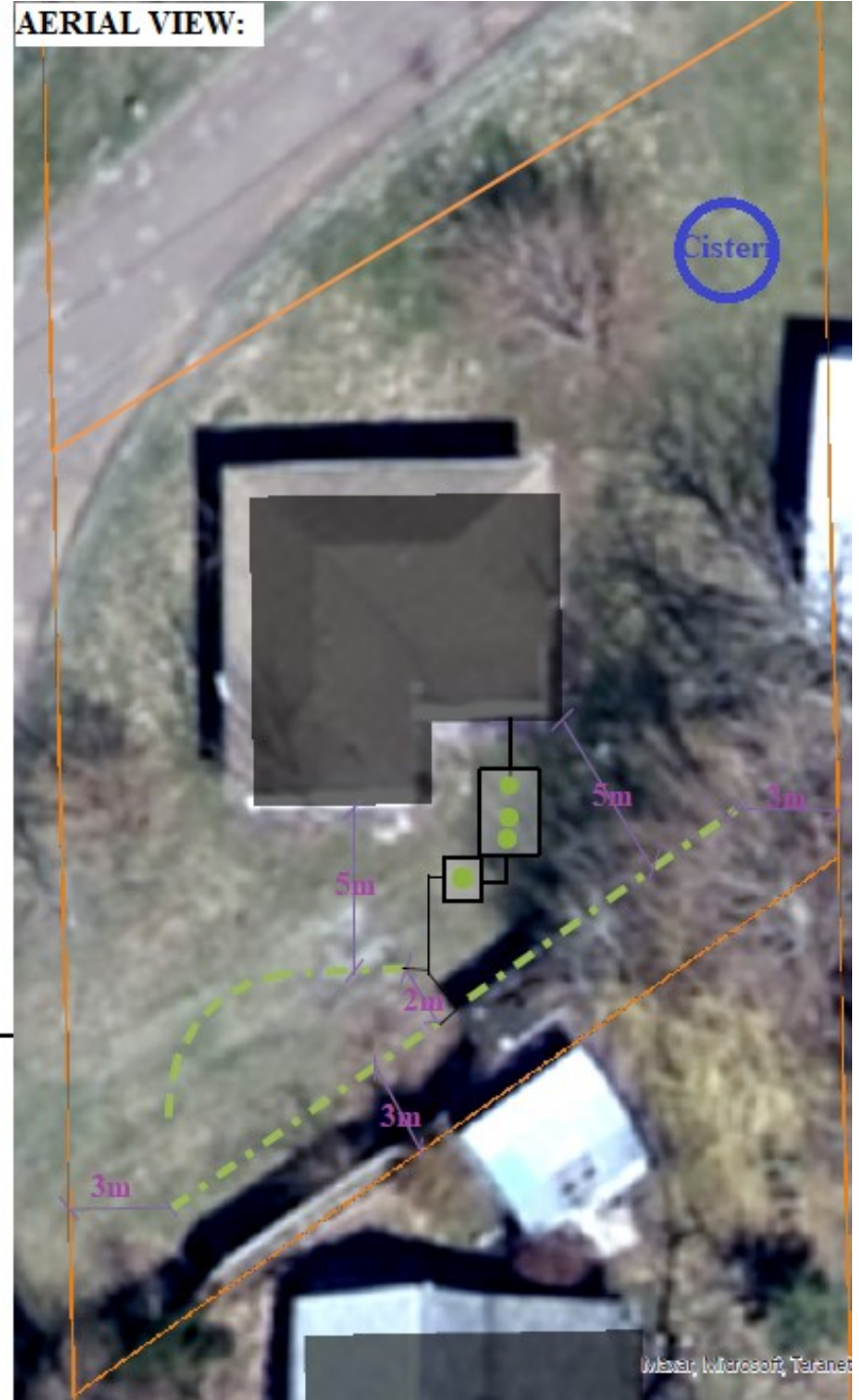

END PROFILE:

